

Injection unit			
Type of injection	IU 850B		
Screw diameter	mm	100	110
Injection pressure	kg/cm <sup>2</sup>	1820	1504
Theoretical shot volume	cm <sup>3</sup>	3927	4752
Shot weight (PS)	g	3574	4324
Theoretical injection volume ( )=Bigger pump unit.	cm <sup>3</sup> /sec	805(1208)	975(1462)
L/D Ratio	L/D	20	18.2
Plasticizing rate (PS)	kg/hr	704	852
Injection stroke	mm	500	
Max. injection speed ( )=Bigger pump unit.	mm/sec	103(154)	
Screw speed	r.p.m	200	
Nozzle contact force	ton	16.5	
Hopper Capacity	l	100	
Cylinder Temperature Control zone	Cylinder ×5 zones . Nozzle ×1 zone		
Clamping unit			
Clamping system	Double toggle		
Clamping force	ton	850	
Opening stroke	mm	1050	
Overall size of platens (H×V)	mm	1560×1660	
Distance between tie-bars (H×V)	mm	1060×1160	
Mould height	mm	450-1100	
Max. daylight opening	mm	2150	
Ejector system	Hydraulic (25 points)		
Ejection stroke	mm	250	
Ejection force	ton	19.8	
General data			
Pump unit ( )=Bigger pump unit.	kw	33+33(33+33+33)	
Heating capacity of screw cylinder	kw	58.3	66.8
Total power capacity ( )=Bigger pump unit.	kw	124.3(157.3)	132.8(165.8)
Oil tank capacity	l	1085	
Net weight(without oil) approx.	ton	n/a	

EB=Energy-Efficient Big Shot Size Series ( )=Bigger pump unit.

We reserve the right to make changes as a result of further technical advantages

# VM 850EB

Mold Dimensions Unit : mm

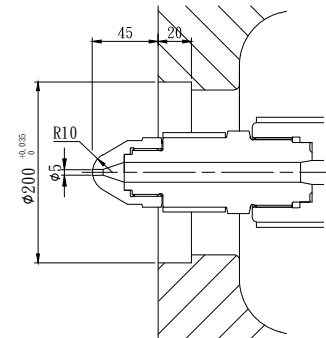
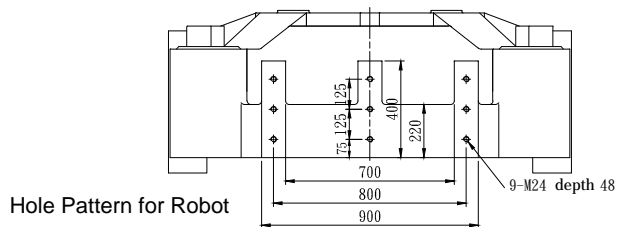
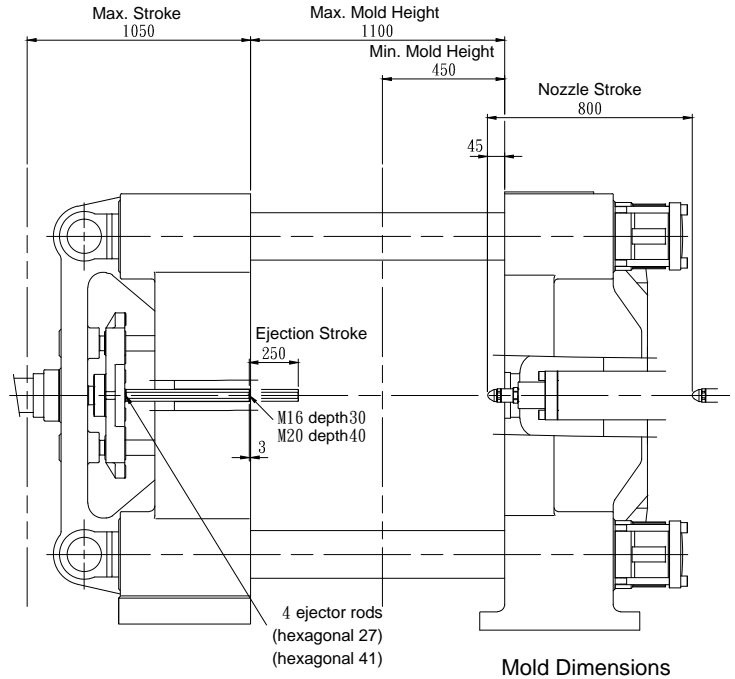
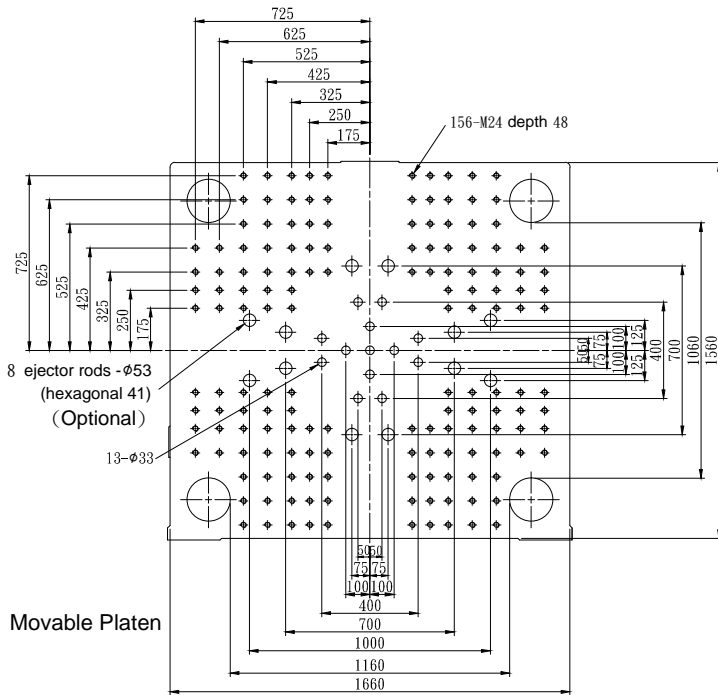

Machine Dimensions Unit : mm

